

MEET THE PRO:

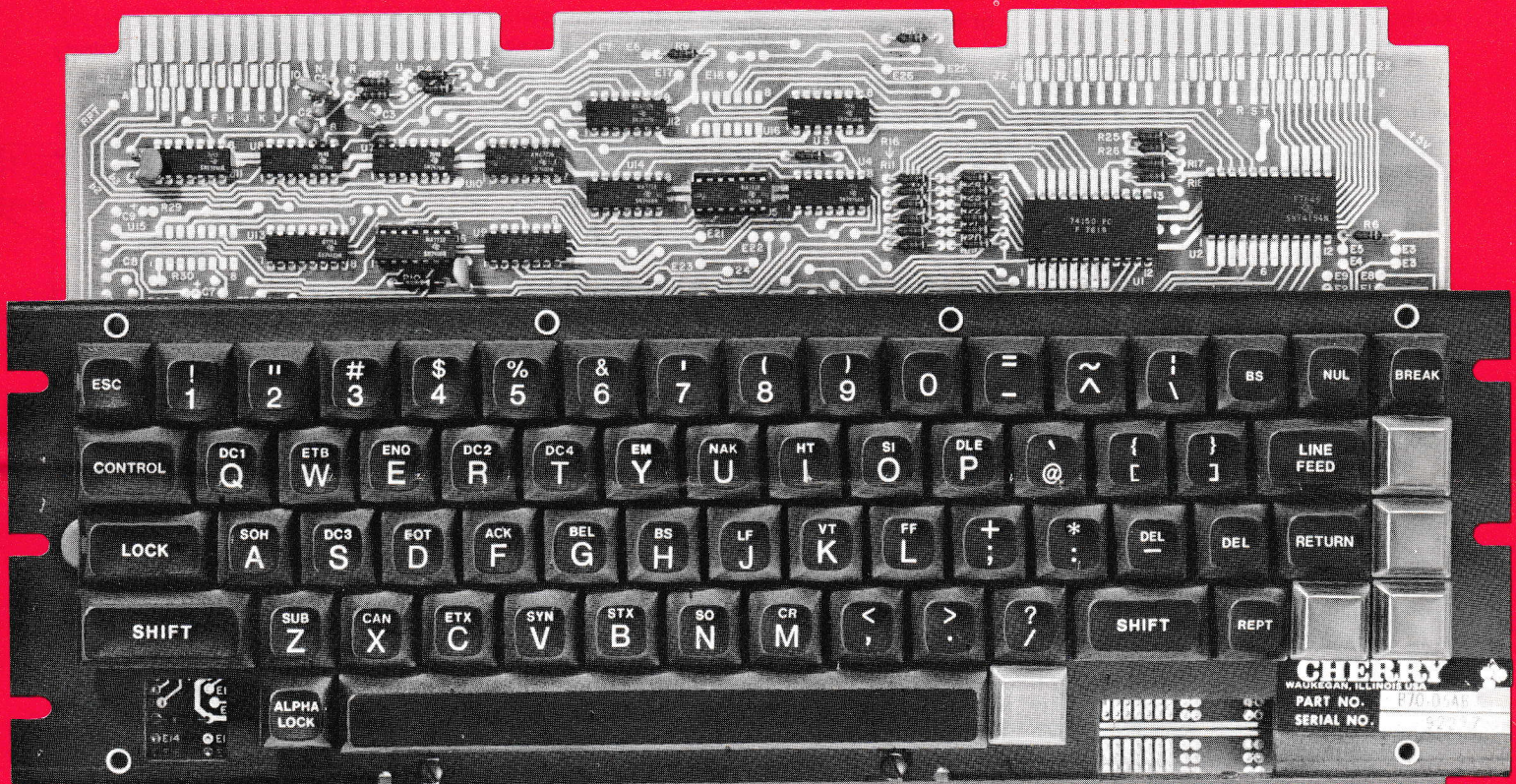

The personal computer keyboard from the
PROfessionals who know keyboards best . . .

CHERRY

- Unique Alpha Lock Key changes keyboard from typewriter to teletypewriter code outputs
- Designed to let you piggyback a "daughter" board . . . easily
- Five unassigned (non-dedicated) re-legendable keys
- Easy, do-it-yourself customizing

HERE'S THE PRO:

The personal computer/hobbyist keyboard from Cherry:
Where every keyboard is backed by a decade of keyboard know-how.

At last! A versatile, reliable, PROfessional-style keyboard especially designed for personal computer and hobbyist applications. A keyboard especially designed with *you* in mind. Designed to provide all the standard features *you* want in a keyboard . . . *plus* special features that permit the PRO keyboard to be applied to a wide variety of systems.

The kinds of systems you are designing and assembling right now in your workshop . . . your office . . . your R&D lab . . . your home. A keyboard designed to be as versatile as you want to make it. And versatile enough to grow as your system grows . . . to be modified to protect you from obsolescence.

Best of all, the PRO is made by Cherry . . . the company with more than a decade of experience in the manufacture and application of commercial and OEM keyboards.

The company that first introduced gold crosspoint contacts to snap action switches for low energy solid state circuits. Then, applied this same innovative gold crosspoint technology to keyboards back in 1967.

When you buy and use a PRO keyboard, you are also buying the skill and craftsmanship that have made the name Cherry the most respected name in keyboards.

CHECK THESE IMPORTANT, UNIQUE STANDARD FEATURES:

- **Full 67 key array**
- **Five user-definable spare keys** with keycaps that have "quick change" clear plastic tops. These keyswitches are not connected electrically, but can be conveniently hard-wired so as to output any code you wish. Traces on the PC board are specifically designed for easy modification with spare holes to facilitate wiring.
- Full 128 character ASCII output code. This is a seven bit code. The eighth bit is available for use as you need . . . parities, shift indicator, whatever.
- **Only one power supply voltage required** — +5 volts at 325 ma. maximum.
- **TTL and DTL compatible output circuitry.**
- **Positive logic with outputs resting low.** Positive logic output code is as indicated in ASCII Code diagram. The keyboard kit is supplied with two SN7408N integrated circuits to be used as U5 and U6 for positive logic (see Keyboard Schematic on pages 4 and 5). The outputs are low when the keyboard is inactive. A low is indicated by a "o".
- **PROfessional-style four mode keyboard.**
 1. **Lower case mode** — providing lower case alpha- numerics.
 2. **Upper case mode** — providing upper case alpha, punctuation and symbols with ASCII encoding. This is accomplished by pressing the shift or shift lock keys.
 3. **Control case mode** — which converts the alpha keys (rows 2, 3 and 4) to control keys. The complete 33 ASCII control codes are available from the keyboard. (See ASCII Code diagram.)
 4. **Teletypewriter Alpha Lock configuration** (Alpha Lock depressed) — where lower case alpha characters are changed to upper case alpha codes. This is "truncated" ASCII, also called the teletypewriter mode since all letters are upper case. (Note: This mode should not be confused with the standard teletypewriter code which is a five bit serial code.)
- **Data Strobe** so that when a key is pressed, the data occur on the output data line b1 to b7. After a delay of 2.5 μ s., the positive going data strobe occurs for 100 μ s. on the STB line. At the same time, a negative going strobe occurs on the \overline STB line. Either or both strobes may be used.
- **Standard 22 pin dual card edge connector** on .156" center. Mating connector type: Cinch 50-44S-20, Dale EB7D-A22TX or equivalent.

B65-64AB

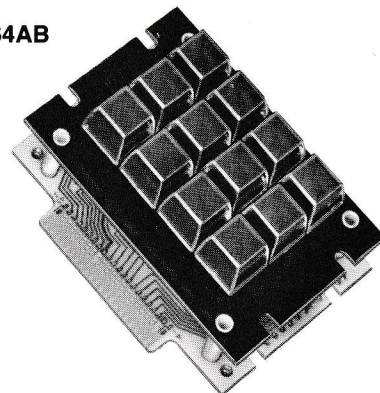

3 x 4 array 12 key auxiliary keyboard with re-legendable keys.

Only the Cherry **PRO** gives you all these important, on-the-spot customizing **SPECIAL FEATURES**

1 Negative Logic — in which the output code will be the complement of the code shown in the ASCII Code diagram. This is accomplished by substituting two SN7400N (not included) integrated circuits for U5 and U6 in the same physical positions as SN7408N. (Note: U5 and U6 are in sockets.) The outputs will rest high for negative logic.

5 Encoded Outputs — Example: Assume you wish the spare key "b16" to generate the code ESC. The output code for ESC from the Code Chart (below) is:

ASCII CODE DIAGRAM
USA STANDARD CODE FOR INFORMATION INTERCHANGE

b7 b6 b5					0 ₀₀	0 ₀₁	0 ₁₀	0 ₁₁	1 ₀₀	1 ₀₁	1 ₁₀	1 ₁₁		
Bits	b4	b3	b2	b1	Row	Col.	0	1	2	3	4	5	6	7
					0	0	0	0	0	0	NUL	DLE	SP	0
0	0	0	0	1	1	SOH	DC1	!	1	A	Q	a	q	
0	0	1	0	0	2	STX	DC2	"	2	B	R	b	r	
0	0	1	1	0	3	ETX	DC3	#	3	C	S	c	s	
0	1	0	0	0	4	EOT	DC4	\$	4	D	T	d	t	
0	1	0	0	1	5	ENQ	NAK	%	5	E	U	e	u	
0	1	1	0	0	6	ACK	SYN	&	6	F	V	f	v	
0	1	1	1	0	7	BEL	ETB	'	7	G	W	g	w	
1	0	0	0	0	8	BS	CAN	(8	H	X	h	x	
1	0	0	0	1	9	HT	EM)	9	I	Y	i	y	
1	0	1	0	0	10	LF	SUB	*	:	J	Z	j	z	
1	0	1	1	0	11	VT	ESC	+	:	K	[k	{	
1	1	0	0	0	12	FF	FS	,	<	L	\	l		
1	1	0	0	1	13	CR	GS	-	=	M]	m	}	
1	1	1	0	0	14	S0	RS	.	>	N	^	n	~	
1	1	1	1	0	15	S1	US	/	?	O	_	o	DEL	

2 Tri State - Positive Logic to let you use two or more PRO keyboards in parallel. Substitute two SN74126N's for use in the U5 and U6 positions. The outputs are high impedance when the keyboard is in the idle state.

3 High Voltage Output — CMOS compatible. Substitute two SN7426N's in the U5 and U6 positions. Wire 8, 6.8K ohm pull up resistors from the 8 data bit output lines to a voltage of +5 to +15 volts, according to the voltage of the equipment which is receiving the data from the keyboard.

Place the resistors in the equipment which is receiving the data. Negative logic will be produced. The signal levels go from the plus voltage to approximately ground. This makes the data CMOS compatible.

The logic levels will rest high when no keys are pressed.

4 Non Encoded Outputs — One side of the five spare keys may be connected to power or ground and the other side may be connected to the spare pins on the connector. If it is desirable to have a pull up resistor in the circuit (similar to the way the BREAK key is shown in the Schematic) the resistors can be soldered into the spare IC position (see Schematic) ... with +5 volts connected to one side of each key module terminal and the other terminal wired to the connector.

Your hard wiring job is simplified because there are holes for the interconnecting wires at the connector, at the spare IC position, and at the spare keys.

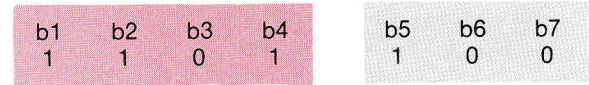

Next, determine the hexadecimal code from the chart below

4 BIT CODE					3 BIT CODE					
Bit Position	1	2	3	4	5	6	7			
Bit Value	1	2	4	8	Hexadecimal	1	2	4	Hexadecimal	
	0	0	0	0	0	0	0	0	0	
	1	0	0	0	1	(Example)	1	0	0	1
	0	1	0	0	2		0	1	0	2
	1	1	0	0	3		1	1	0	3
	0	0	1	0	4		0	0	1	4
	1	0	1	0	5		1	0	1	5
	0	1	1	0	6		0	1	1	6
	1	1	1	0	7		1	1	1	7
	0	0	0	1	8					
	1	0	0	1	9					
	0	1	0	1	A					
	1	1	0	1	B (Example)					
	0	0	1	1	C					
	1	0	1	1	D					
	0	1	1	1	E					
	1	1	1	1	F					

Locate the first digit (B) in the parenthesis within the outline of U2 on the Schematic (HEX notation). Connect this point to one side of the key "b16". If a key is already connected there, the second key may be connected in parallel.

Locate the second digit (1) in the parenthesis within the outline of U1 on the Schematic (HEX notation). Note: You will find a column running from (0) thru (7) immediately below a column running from ((0)) thru ((7)). If you wish to have the ESC code dedicated — that is, never capable of being shifted — choose ((1)). If you want the ESC code to shift, choose (1). If you do choose to connect to (1), the ESC code will shift according to the ASCII Code Chart rules.

Connect the selected (1) or ((1)) to the other terminal at key "b16".

THE PRO

SCHEMATIC DRAWING

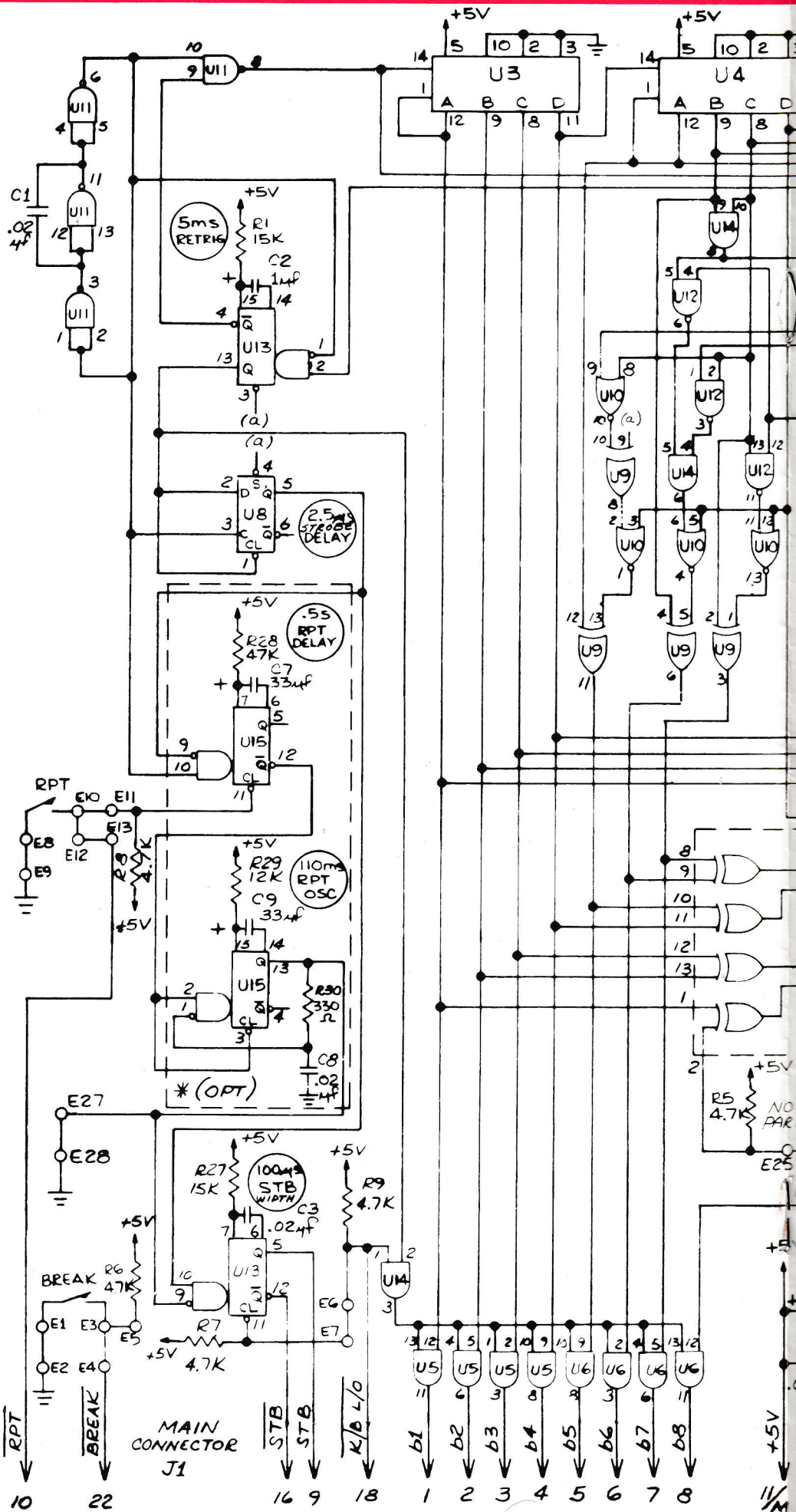

PIN NUMBERS TYP.
NOT LABELED
ON PC BOARD.

MATRIX
EXPANSION
CONNECTOR
J2

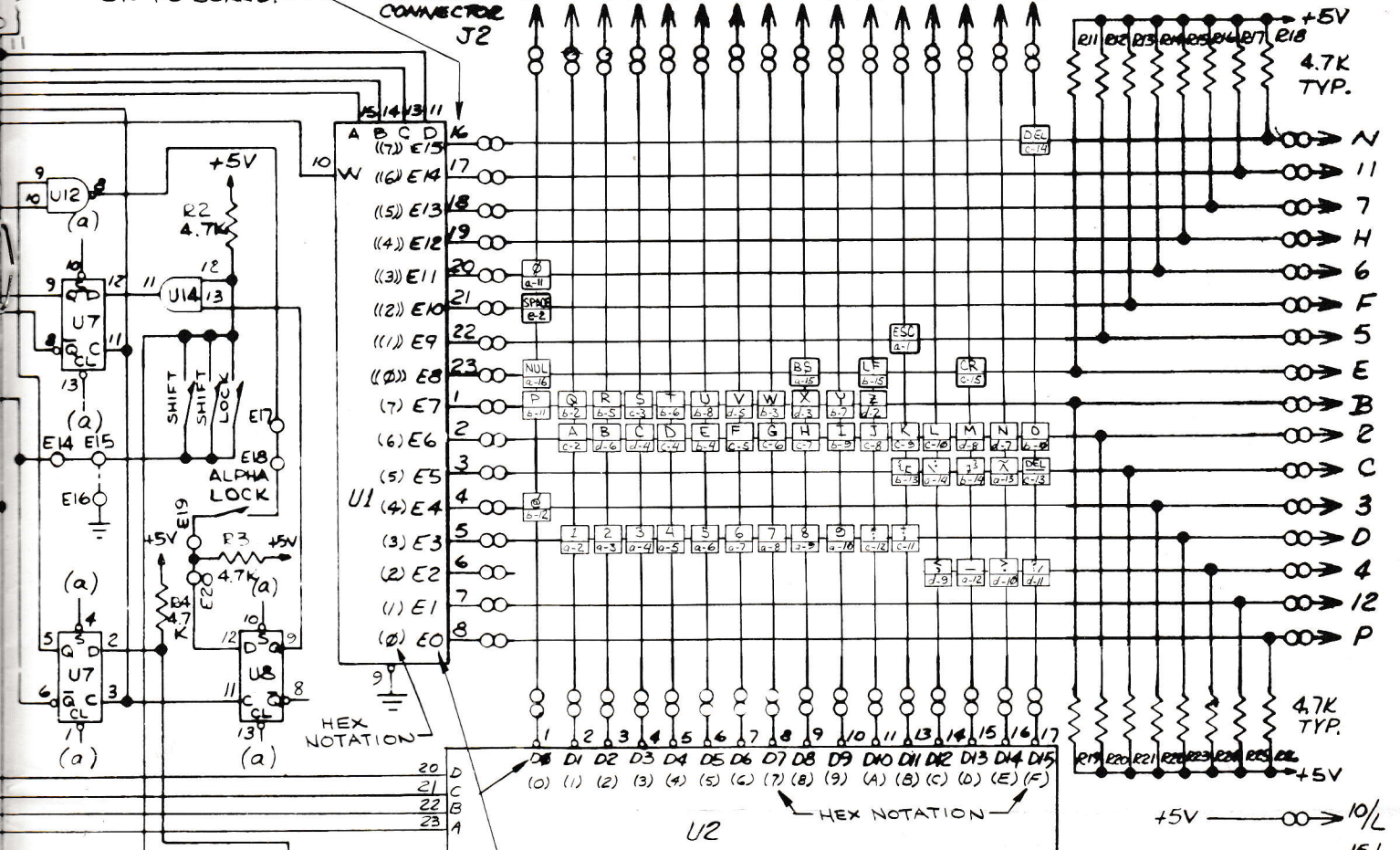

HEX NOTATION

THESE NUMBERS
APPEAR ON
PC BOARD.

U2

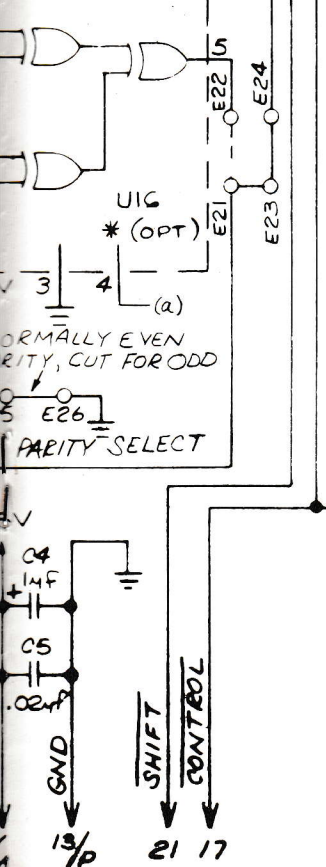

SPARE SWITCHES

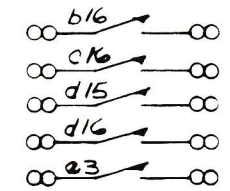

SPARE I.C. (16 P)

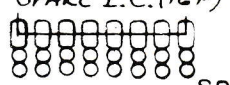

EACH SQUARE IN THE
MATRIX ABOVE
REPRESENTS THIS
TRACE PATTERN ON
THE PC BOARD.

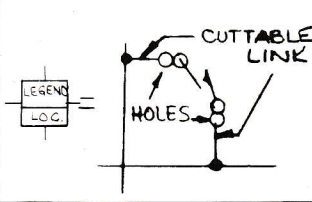

SPARE PINS ON CONNECTOR

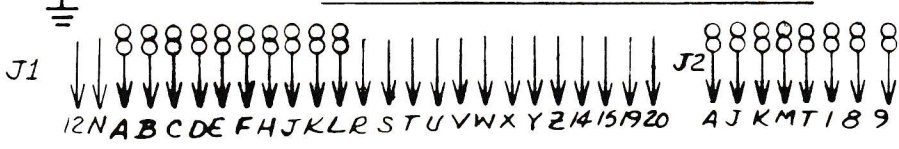

REF. DES.	INDUSTRY NO.	+5V	END
U1	74150	24	12
U2	74154	24	12
U3, U4	7493	5	10
U5, U6	7408	14	7
U7, U8	7474	14	7
U9	7486	14	7
U10	7402	14	7
U11	MC846	14	7
U12	7400 or MC3000	14	7
U13	74123	16	8
U14	7408	14	7
U15	74123	16	8
U16	74180	14	7

CHERRY B70-05AB KEYBOARD

6 Flexible Key Assignments — When it is desired to change the code of a key which comes factory wired, first locate the key module terminal solder connections on the bottom of the printed circuit board. There is a trace coming from each of the key's solder connections to two pads with two plated-through holes.

Do not cut this trace. Instead, find the trace which comes from the two plated-through holes to one plated-through hole. Cut this trace on each of the two key connections to isolate the key so it can be wired to another matrix position.

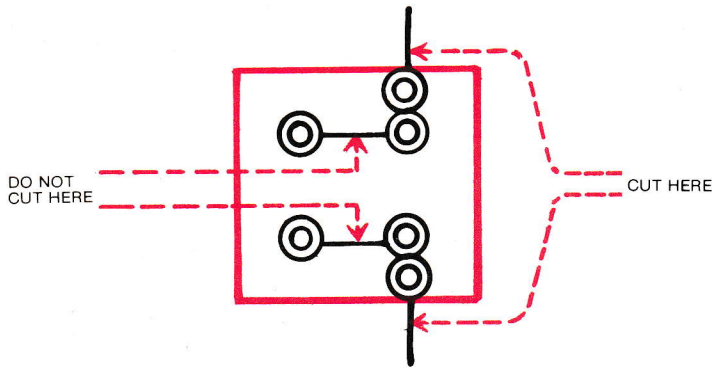

- Solder one wire to one of the two (double) plated-through holes coming from one side of the switch.
- Solder another wire to one of the two (double) plated-through holes.
- Make sure the solder heat is sufficient to flow the solder on to the printed circuit pad.
- Apply the minimum amount of solder to the connection to prevent any solder from "wicking" through the holes and possibly shorting on the top side of the PC board.
- Connect the two wires from the key to the keyboard matrix as described in number 5 (Encoded Outputs).

It is also possible to isolate the Alpha Lock key, Repeat key and Break key and use them for other purposes. The keys are isolated by cutting traces between two "E" terminal points as shown on the schematic, soldering two wires to the isolated E pads, and connecting them to the matrix as described in number 5 (Encoded Outputs).

7 Provisions for an Auxiliary Keyboard — The matrix which is shown in the upper right hand side of the Schematic has both vertical and horizontal connections linked to an auxiliary edge connector J2. There are wire holes in each card edge finger connection so that the main keyboard circuitry may be extended to the auxiliary keyboard with either a connector or soldered wires.

There may be any reasonable number of additional auxiliary keyboard keys connected in parallel with the keys which are supplied with the keyboard or the additional keys may be connected to revised matrix positions.

Since electronic signals from these are pulse circuits, it is recommended that the additional keys be adjacent to the keyboard to prevent the pickup of excessive amounts of noise.

8 Auxiliary Keyboards — Optional auxiliary keyboards are available. An auxiliary keyboard is connected to the main keyboard with the electronics by means of wires or flexible cable to the main keyboard J2 connector. A 12 key daughter board is available from Cherry. It is our part number B65-64AB.

9 Automatic Repeat — The keyboard is supplied with a repeat key which provides a ground for an external circuit. If it is desirable to have an automatic delayed strobe repeat, the following changes may be made:

- Add U15 (SN74123N) to the printed circuit board
- Add R28 (47K), R29 (12K), R30 (330 ohms)
- Add C7 (33uf), C8 (.02uf), C9 (33uf)
- Cut jumper E27 to E28
- Connect E10 to E11

This automatic repeat circuit generates additional strobe pulses after the initial pulse which occurs when the key is pressed. If the key is held down, there is a pause of .5 seconds before additional strobe pulses occur at 9 cycles/second (see Data Output Timing chart). The .5 second delay can be varied by changing R28 and C7. The delay is proportional to the values of R&C. The range of R is 4.7K to 47K. Reducing R to 1/2 its value reduces the repeat delay to approximately 1/2 of .5 second or .25 second.

The capacitance C7 may be increased or decreased to change the repeat delay. There is no range limit for the capacitors. The repeat frequency of 9 cycles/second may be varied by changing R29 and C9. R29 can be any value from 4.7K to 47K. C9 may be increased to increase the period of the repeat pulses — or decreased to reduce the period. There is no range limit for the capacitors.

To calculate the width (t_w) of the output pulse from the mono-stable multivibrators SN74123N, use the following formula:

For $c > 1000\text{pF}$, the output pulse width (t_w) is defined as:

$$t_w = .32 \times R_t \times C$$

R_t is in K Ω

C is in pF

t_w is in nanoseconds

DATA OUTPUT TIMING CHART

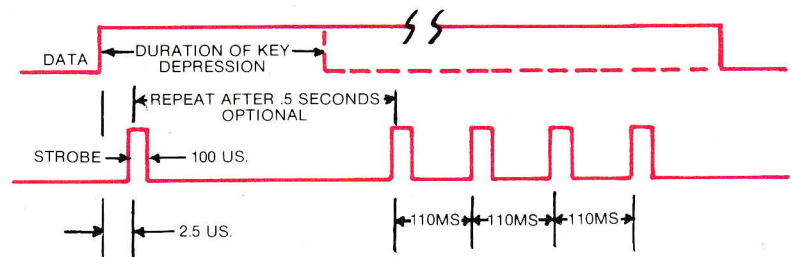

10 Strobe Pulse Width — The keyboard as supplied will generate a STROBE and $\overline{\text{STROBE}}$ pulse width of approximately 100 microseconds. To vary the pulse width, change the value of R8 and/or C3. R8 may be any value from 4.7K to 47K. The pulse width will change in proportion to the resistor value. For large changes in pulse width, change C3 to .002 mfd for approximately a 10 microsecond pulse . . . or change C3 to .2 mfd for a pulse width of approximately 1 millisecond.

11 Optional Parity Bit — The basic keyboard output code is seven bit ASCII. The eighth bit, as provided by the keyboard, indicates whether or not the character is shifted from lower case to upper case.

With positive logic, the bit is high for the non-shifted characters and low for the shifted characters.

Some systems require odd or even parity as the eighth bit. To incorporate parity in the keyboard, add U16, SN74180 Odd/Even parity generator. Cut the trace between E23 and E24,

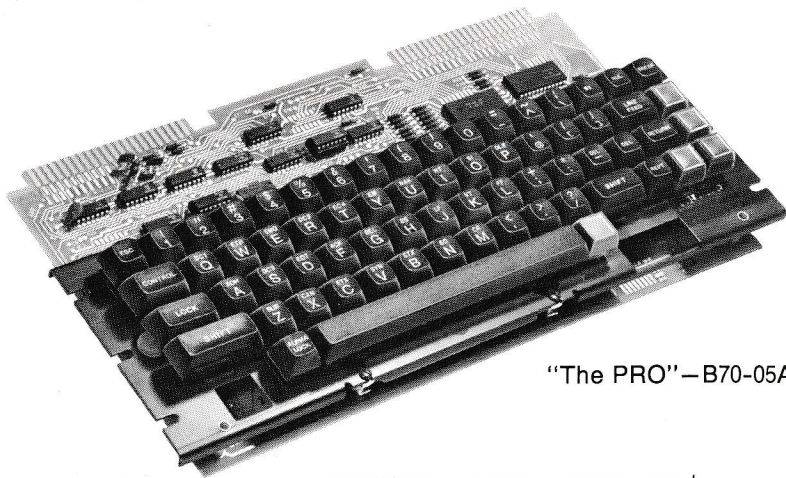

"The PRO" - B70-05AB

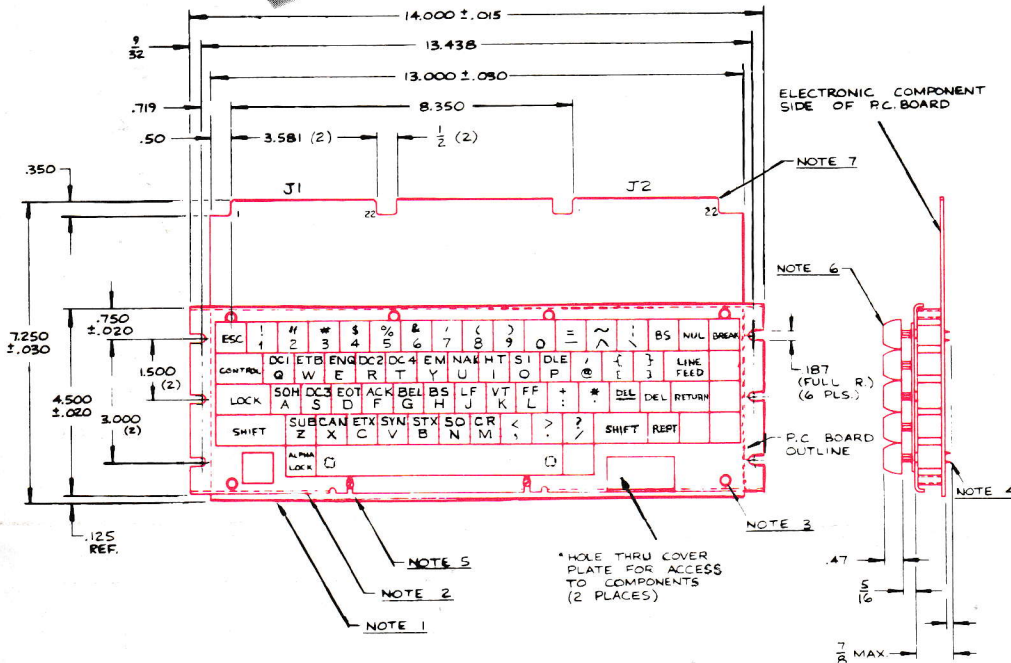

RECOMMENDED PANEL CUTOUT

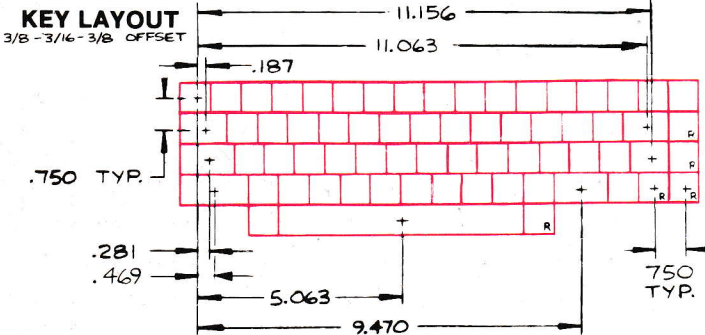
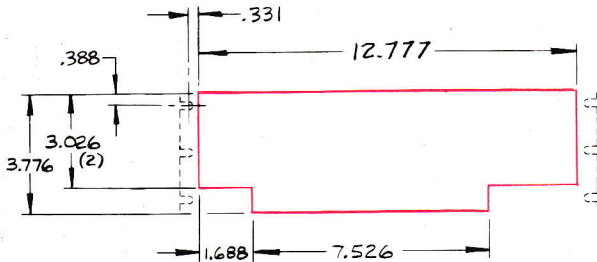

PIN NO.	MAIN CONNECTOR J1	MATRIX EXPANSION CONNECTOR J2
1	BIT 1 (OUT)	SPARE
2	BIT 2	E6
3	BIT 3	E4
4	BIT 4	E2
5	BIT 5	E9(1)
6	BIT 6	E11(3)
7	BIT 7	E13(5)
8	BIT 8	SPARE
9	STROBE (OUT)	SPARE
10	REPEAT (IN/OUT)	-5VDC
11	+5VDC (IN)	E14(6)
12	NOT USED	E1
13	GROUND (IN)	DØ
14	SPARE	D2
15	SPARE	GROUND
16	STROBE (OUT)	D15 (F)
17	CONTROL (IN/OUT)	D13 (D)
18	K.B. LOCK OUT (IN)	D11 (B)
19	SPARE	D4
20	SPARE	D6
21	SHIFT (IN/OUT)	D8
22	BREAK (OUT)	D10 (A)
A	SPARE	SPARE
B		E7
C		E5
D		E3
E		E8(Ø)
F		E10(2)
H		E12(4)
J		SPARE
K		SPARE
L	SPARE	+5VDC
M	+5VDC (IN)	SPARE
N	NOT USED	E15(7)
P	GROUND (IN)	EØ
R	SPARE	D1
S		GROUND
T		SPARE
U		D14(E)
V		D12(C)
W		D3
X		D5
Y		D7
Z	SPARE	D9

G, I, O AND Q PIN DESIGNATIONS ARE NOT USED

NOTES:

- 1-P.C. board mat'l: .062 ± .007 thk. G10 glass epoxy 1 oz. copper clad on 2 sides.
- 2-Cover plt. mat'l: .063 ± .005 black anodized aluminum.
- 3-Spacer mat'l: 1/4 dia. aluminum.
- 4-Key modules and electronic components are wave soldered to P.C. board.
- 5-Space bar anti-wobble pivot area (assembled to cover plt.)
- 6-Keycaps are two shot molded truncated pyramid with a concave top, except for relegendables, which are two pieces.
- 7-Connectors (2) are card edge type. Contacts are nominal .156 centers. For pin assignments see table. J1 connector may be single or dual readout or tuning fork type 22 pin. J2 auxiliary connector must be dual only (44 total pins).

MECHANICAL SPECIFICATIONS OF KEY MODULES

- A-All keys are momentary action except for keys "lock" and "alpha lock" which are alternate action.
- B-Pretravel: 3/32 = 1/32
- C-Total travel: 3/16 max.
- D-Contacts: gold cross point.
- E-Oper. force: 2-1/2 = 1/2 oz. except as follows:
"Lock" & "alpha lock" keys are alternate action and have oper. force of 2 to 4-1/2 oz.
- F-Keycap colors: matte black / white legend.
- G-Relendable keycap color: black base / matte clear color.



CHERRY ELECTRICAL PRODUCTS CORP.
3600 Sunset Avenue, Waukegan, Illinois 60085
PHONE: 312/689-7700—TWX: 910/235-1572

SWITCHES and KEYBOARDS - Available locally from authorized distributors.