

Keyboard designed with Multifunction keys KFK-EB9HY, -EC0HY, -EC4HY

(PC-AT Compatible 104, 105, 109 Keys + Multifunction 15 keys)

FEATURES

1. PS-2 compliant keyboard designed for Windows®.
2. Convenient multi-function keys(15 keys).
3. Meets rigorous safety standards in all countries.
Certified to comply with FCC part 15 class 'B' limits.
Also UL, cUL, TÜV, and CE standard.
4. Quiet sound, with a real key touch feeling.
5. Laser printed characters can be recycled in order to protect the environment.
6. Straight cord with Mini-DIN type 6 contacts connector included.
7. Adjustable tilt mechanism.

* "Windows®" is registered trademark of Microsoft corp.
"PC-AT" is registered trademark of International Business Machines corp.



SPECIFICATIONS

Item	Specifications
Keyboard Inclination	Step sculpture type
Key Row Offset	9.50-4.75-9.50mm (Keypitch 19.00)
Key Travel	4.2mm
Output Level	TTL Compatible
Output Signal	Transmission of serial data is compatible with the PC/AT Make-break key code transmission.
Supply Voltage	Voltage: +5V±0.25V DC Current: 100mA max.

DIMENSIONS

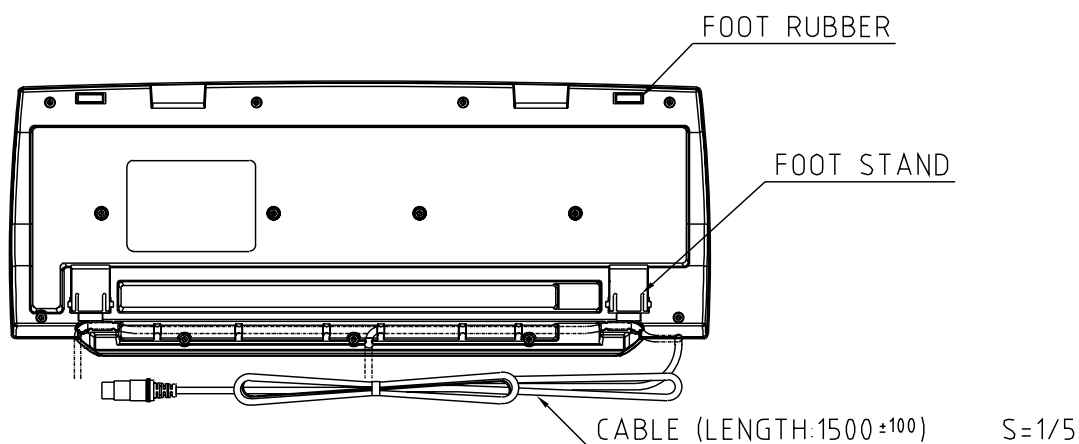
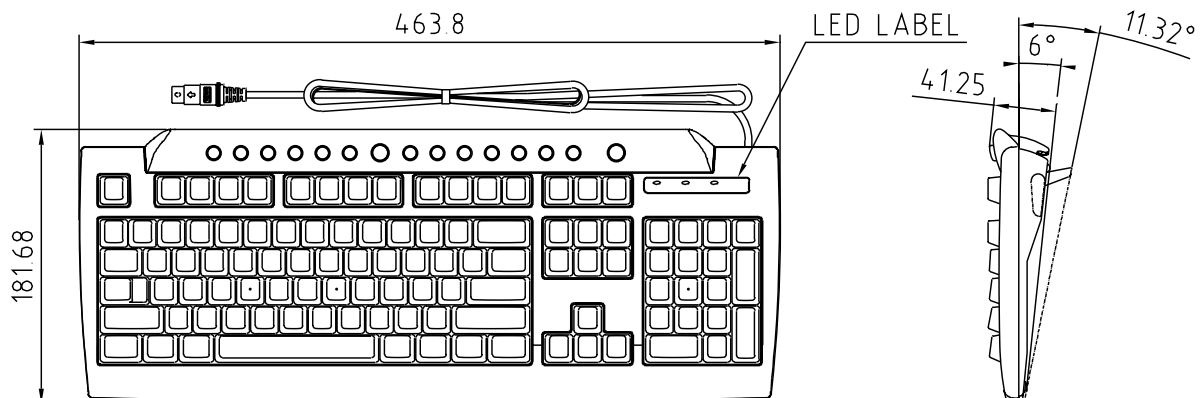

6PIN MINI-DIN CONNECTOR

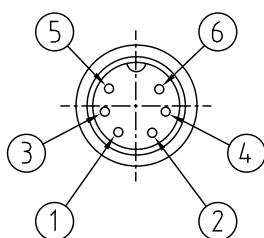

Terminals

Pin No.	Signal
1.	Date
2.	N. C
3.	GND
4.	Vcc (+5V)
5.	Clock
6.	N. C

KEY LAYOUT

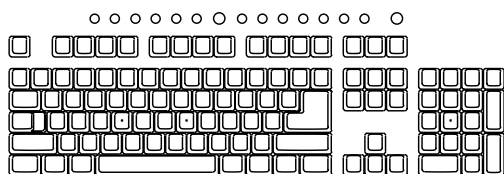

BIG ENTER 104 KEYBOARD

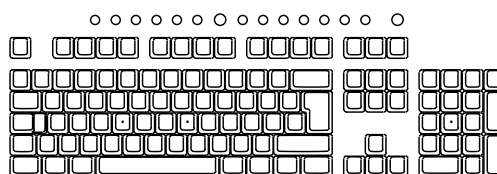

STANDARD ENTER 105 KEYBOARD

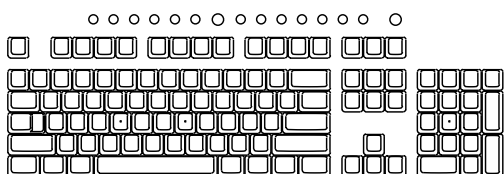

STANDARD ENTER 104 KEYBOARD

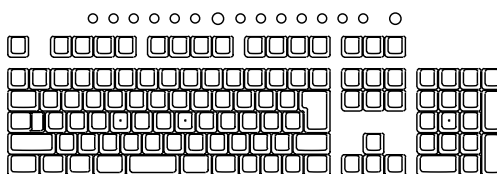

STANDARD ENTER 109 KEYBOARD