

# ESM.

European Switches Manufacturing

## REED

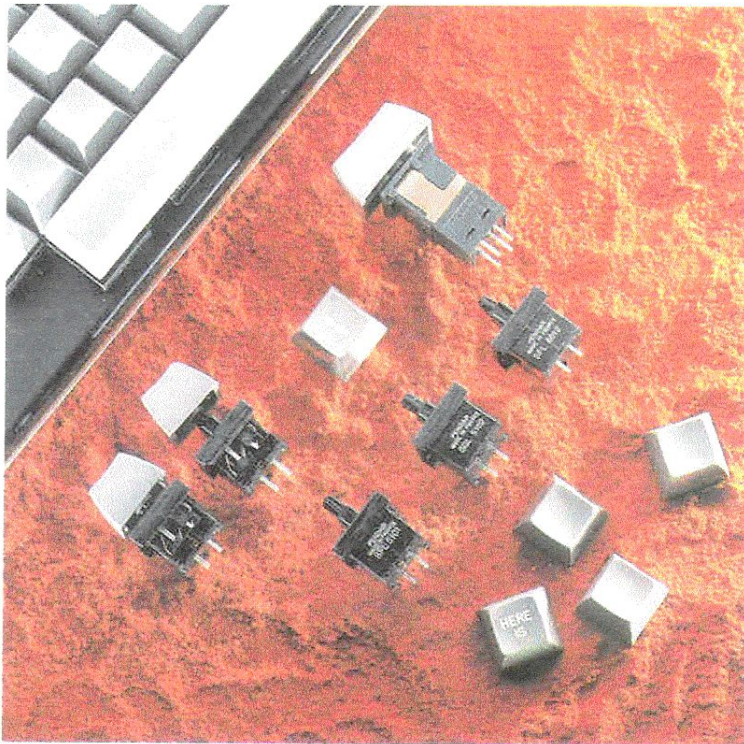

## KEYSWITCHES

17-19 Rue Mathutin 59127 Elincourt - France  
Tel. : +33 3 27 37 69 25 Fax. : +33 3 27 74 62 31

## REED SWITCHES-HIGH PROFILE SERIES

### SPECIFICATIONS

#### CONTACT ARRANGEMENT

- 1 form A: SF, SG/SK, SI/SH
- 2 form A: SF

#### SWITCHED POWER

5 VA resistive maximum

#### VOLTAGE

100 Vdc maximum

#### CURRENT

300 mA maximum

#### INITIAL CONTACT RESISTANCE

< 250 milliohms

#### DIELECTRIC STANDOFF (capsule)

200 Vdc - 150 Vrms

#### CONTACT BOUNCE

500  $\mu$ S maximum

#### LIFE EXPECTANCY (operations)

> 50 x 10<sup>6</sup>: SF, SI/SH  
> 5 x 10<sup>6</sup>: SG/SK

#### OPERATING TEMPERATURE

-20° to +60°C

#### STORAGE TEMPERATURE

-30° to +70°C

#### VIBRATION

(no mechanical damage; non operating test) 10 g;  
1.5 mm amplitude; 10-2000 Hz.

#### SHOCK

(no mechanical damage; non operating test) 50 g;  
11 ms (1/2 sine wave).

#### PLUNGER TRAVEL

5 mm: SF, SI/SH  
5.5 mm: SG/SK

#### PRETRAVEL

1.9 mm: SF, SI/SH  
2.1 mm: SG/SK

#### OVERTRAVEL

0.8 mm: SF, SI/SH  
1.5 mm SG/SK

#### RELEASE POINT

1.0 mm: SF, SI/SH  
1.2 mm: SG/SK

#### NON-RELEASE POINT

3.0 mm  $\pm$  0.2 mm: SG/SK

#### OPERATING FORCES

SF, SI/SH: 50  $\pm$  10 gr  
80  $\pm$  15 gr  
130  $\pm$  20 gr  
200  $\pm$  40 gr

SG/SK: 50 gr nom.  
80 gr nom.  
130 gr nom.  
200 gr nom.

#### MATERIAL (except plunger)

Self extinguishable class SE0

#### CONNECTING PINS

New silver

#### CLIP FOR PANEL MOUNTING

Stainless steel

### SF, SG, SI, SK AND SH SERIES

Momentary (SF) and push-push (SG) versions are available. Illuminated momentary (SI) and illuminated push-push (SK) versions are designed for use as a control key. The SI version can be provided without lamp terminals (SH).

The lamp is located centrally under the keytop giving optimum brightness. Only SF switches can have 2 form A configuration. Lamp terminals are always in position 3-4.

### DIMENSIONS

In mm M = 2.54 mm

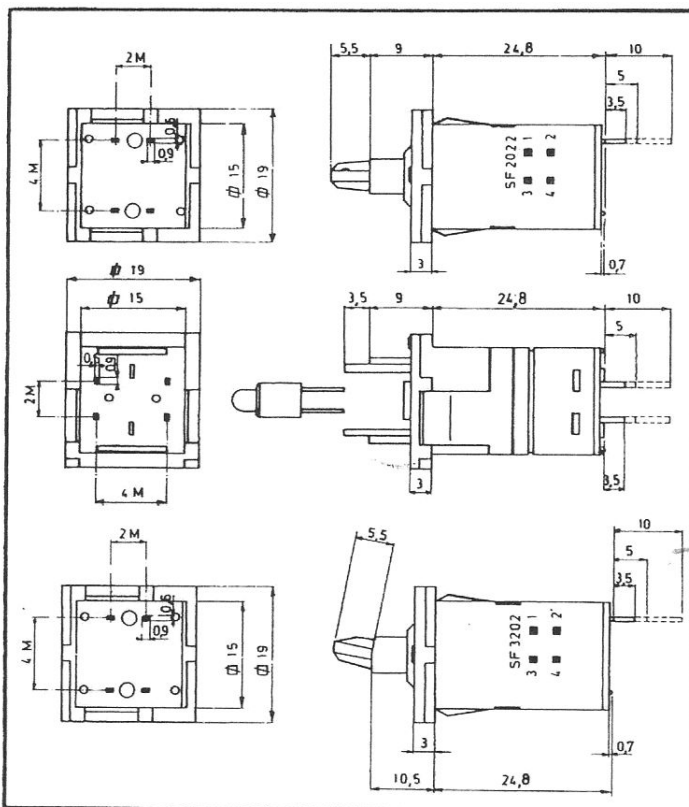

### PANEL CUTOUT

Maximum panel thickness: 2 mm

$\varnothing +0.1$   
15.12 - 0

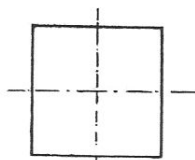

# REED SWITCHES-LOW PROFILE SERIES

## SPECIFICATIONS

**CONTACT ARRANGEMENT**  
1 form A

**SWITCHED POWER**  
3 VA resistive maximum

**VOLTAGE**  
100 Vdc maximum

**CURRENT**  
300 mA maximum

**INITIAL CONTACT RESISTANCE**  
< 300 milliohms

**DIELECTRIC STANDOFF (capsule)**  
200 Vdc - 140 Vrms

**CONTACT BOUNCE**  
1 mS maximum

**LIFE EXPECTANCY (operations)**  
> 50 x 10<sup>6</sup>: SFL, SIL  
> 1 x 10<sup>6</sup>: SGL

**OPERATING TEMPERATURE**  
- 20° to + 60° C

**STORAGE TEMPERATURE**  
- 30° to + 70° C

**VIBRATION**  
(no mechanical damage; non operating test) 10 g;  
1.5 mm amplitude; 10-2000 Hz.

**SHOCK**  
(no mechanical damage; non operating test) 50 g;  
11 ms (1/2 sine wave).

**PLUNGER TRAVEL**  
4 mm

**PRETRAVEL**  
0.9 mm

**OVERTRAVEL**  
0.5 mm: SFL, SIL  
1.1 mm SGL

**RELEASE POINT**  
0.5 mm

**OPERATING FORCES**  
SFL, SIL: 50 ± 10 gr  
80 ± 15 gr  
SGL: 50 gr nom.  
80 gr nom.

**MATERIAL (except plunger)**  
Self extinguishable class SE0

**CONNECTING PINS**  
New silver, tinned.

## SFL, SGL, SIL SERIES

The Low Profile SFL Series uses the same reliable reed contact as the SF and is available in momentary, alternate action, incandescent lighted and LED lighted. Their design is such that they can easily be used to form small or large keyboards. Each SFL switch can use the same keyboard hardware (PCB, frame) as used for the SF when lower profile is required. For stepped keyboards, keyswitches are provided with 11° plunger angle.

## DIMENSIONS

In mm M = 2.54 mm

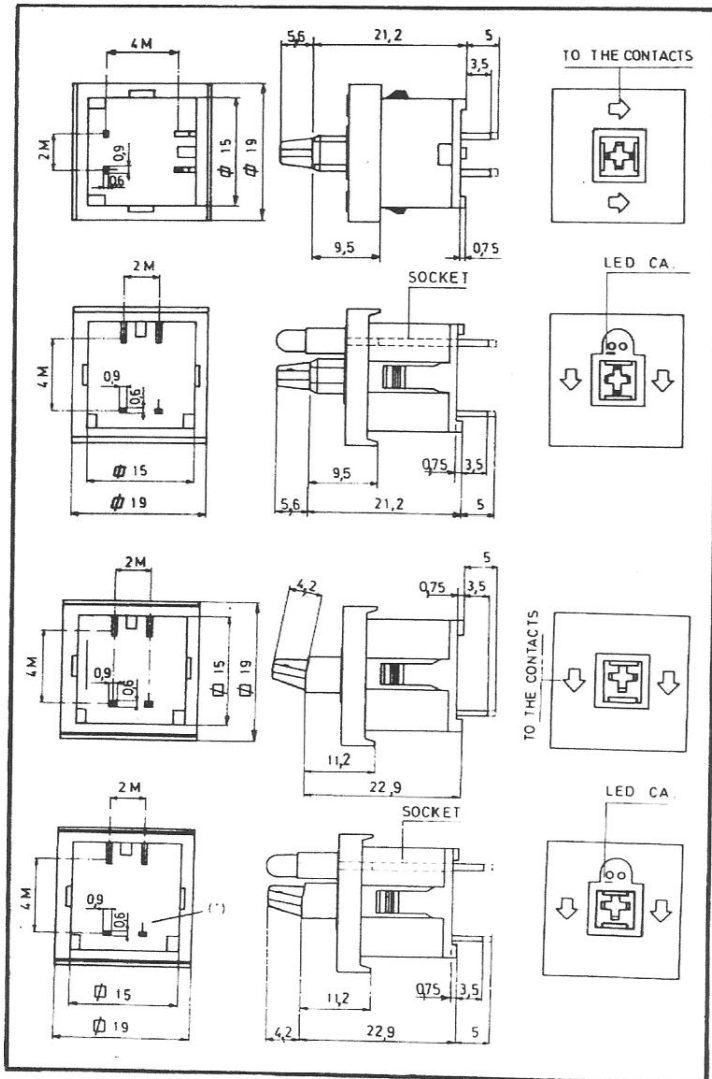

(\*) Serial diode connection: cathode side

## PANEL CUTOUT

Maximum panel thickness: 1.5 mm

± 0.1  
15.12 - 0

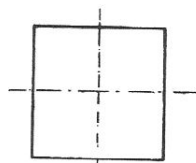

# ORDERING INFORMATION - REED KEYSWITCHES

## SFL SERIES

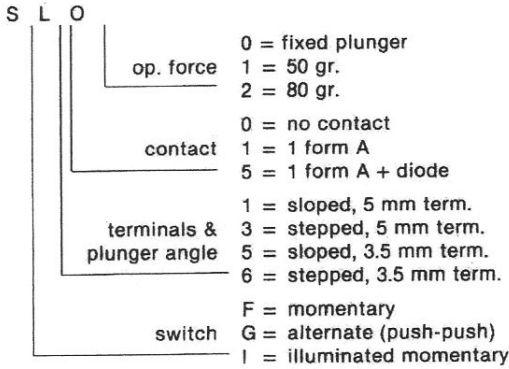

Example:  
 SGL6102 is a low profile keyswitch (alternate action), stepped and 3.5 mm terminals, 1 form A and 80 gr. operating force.

### LAMPS FOR SIL SERIES

- T1 bi-pin standard
  - 5V-75 mA Ref. 104577-00
  - 12V-60 mA Ref. 104577-01
  - 18V-26 mA Ref. 104577-02
  - 28V-24 mA Ref. 104577-03

### • LED T1 type

- Red Ref. 104139-00
- Orange Ref. 104-139-01
- Yellow Ref. 104139-02
- Green Ref. 104139-03

- Adapter for LED Ref 104293-00

## SF SERIES

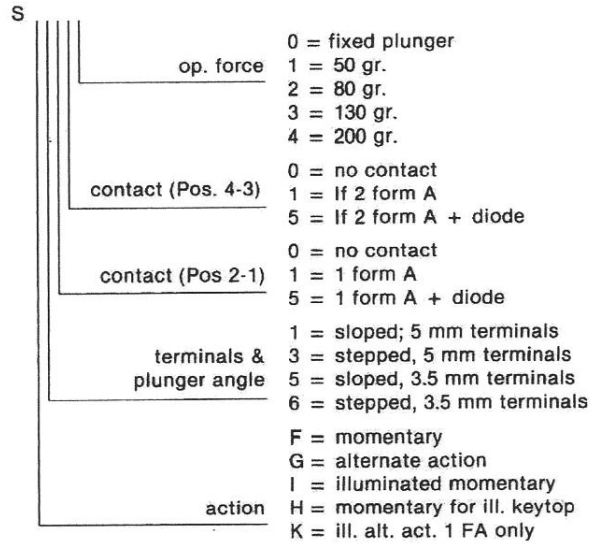

Notes: 1) For illuminated keyswitch; lamp terminals will be in position 3-4

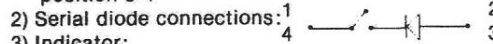

3) Indicator:  
 SI 1000 & SI 5000 only.

Example: SK3101 is an illuminated keyswitch; alternate action stepped and 5 mm terminals 1 form A and 50 gr. alternate force.

### LAMPS FOR SI & SK SERIES

T-1 bi-pin base lamp with following characteristics:

- 5V-75 mA Part number 100690-00  
Lamp base: black
- 12V-60 mA Part number 100690-01  
Lamp base: brown
- 28V-24 mA Part number 100690-02  
Lamp base: grey
- 18V-26 mA Part number 100690-03  
Lamp base: blue

# ACCESSORIES FOR REED KEYSWITCHES

## HARD RUBBER SPACER

For fitting alongside space bar mechanism at end opposite to switch. This provides a uniform maximum travel at either end of space bar. Can also be used to fill unused holes in frame.  
Part number: 102712-00

## HIGH PROFILE SPACER

This is one module black square plastic moulded spacer for filling open areas between switches up to the level of keytop bottom.  
Part number: 102032-00

## BLOCKING RING

- prevent the plunger from moving
  - these plastic rings snap over the key switch plunger.
- For SF & SG: part number: 102795-00  
For SFL & SIL: part number: 105014-00

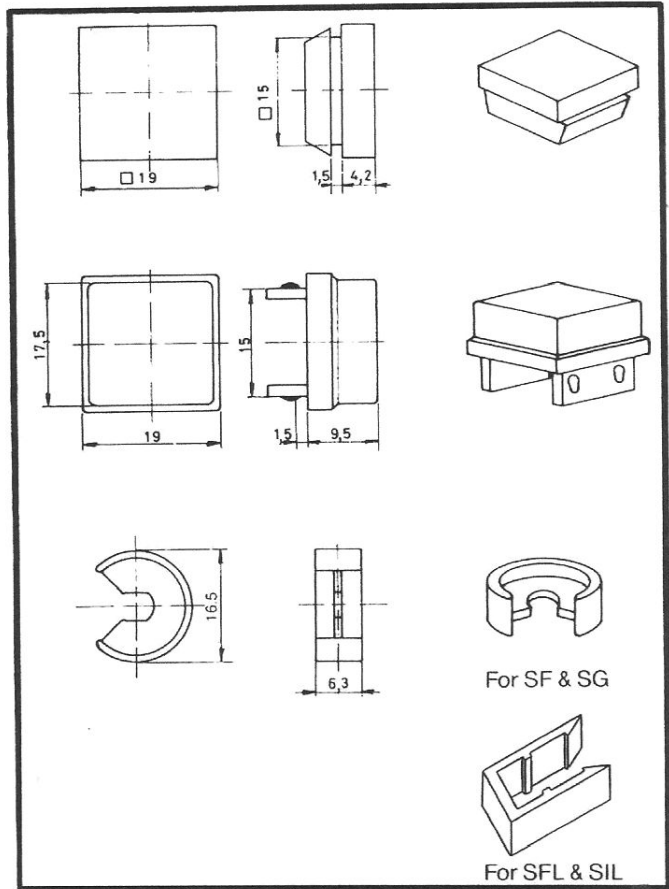

# SPACE BAR MECHANISM FOR REED KEYSWITCHES

This is a parallel movement component to operate a key-switch mounted alongside. Part number 104607-00.  
A BA 8-8 units space bar is available (see BA Series) for fitting to it. The space bar mechanism 104609-00 is the angled version 11°.

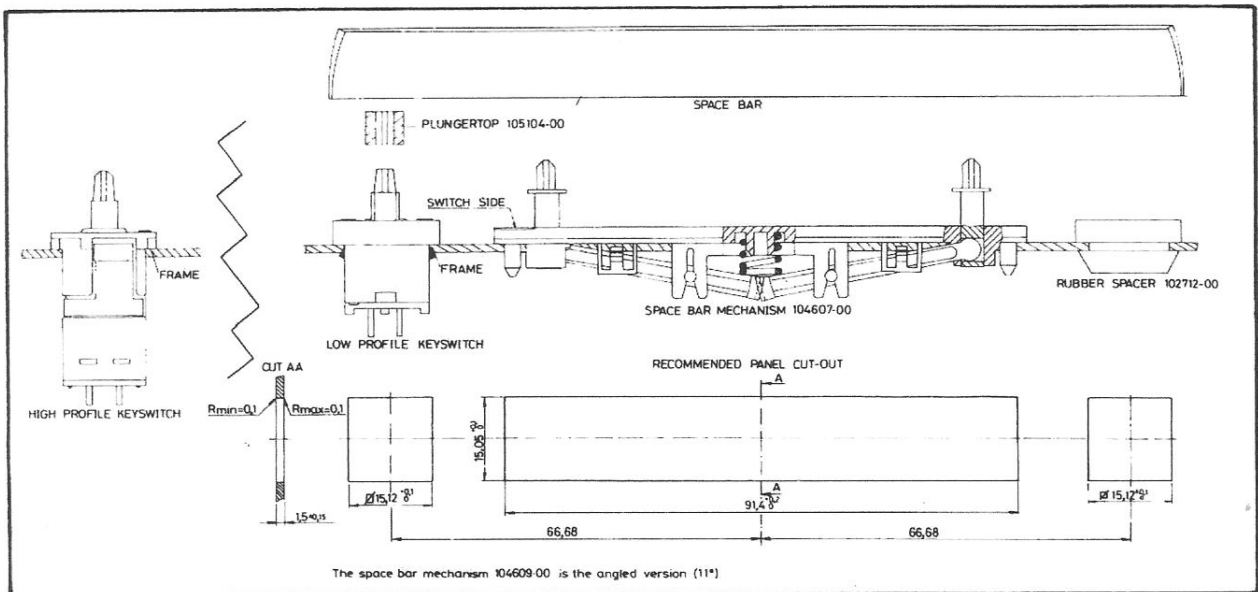

# STANDARD KEYTOPS

A wide range of keytops in many sizes and colour combinations is available. A growing library of legends for double-shot moulded keytops can satisfy your individual requirements.

## BLANK AND DOUBLE-SHOT MOULDED KEYTOPS

Unit: 1x1 unit (BA1)  
 1x1.5 unit (BAB)  
 1x2 units (BA2)  
 1x3 units (BA3)

Keytop finish: mat top

Std colour combination: shell: medium grey (H1)  
 legend: white (T1)

Material: A.B.S.

### NOTE

Other shapes and sizes are also available such as 1 1/4 key-top, 1 x 1 3/4 unit keytop, 2 level keytop; etc.

### STANDARD COLOURS

Dark grey (D1), light grey (X1) and medium grey (H1)

### AVAILABLE COLOURS

B1	blue	O1	orange
D1	dark grey	R1	red
E1	beige	T1	white
G1	green	X1	light grey
H1	medium grey	Y1	yellow
M1	brown	Z1	black

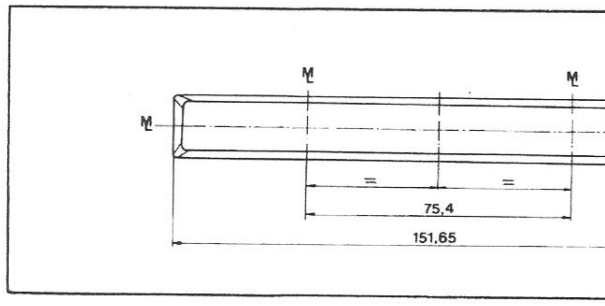
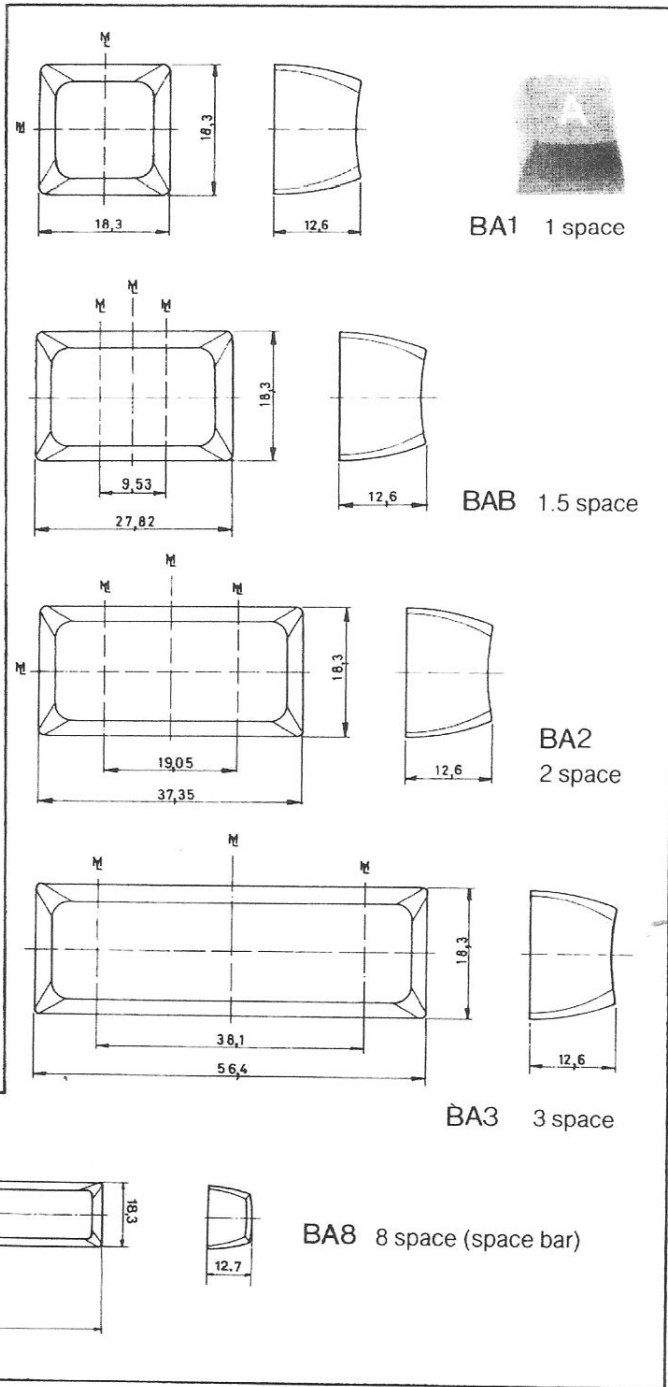

### ORDERING INFORMATION

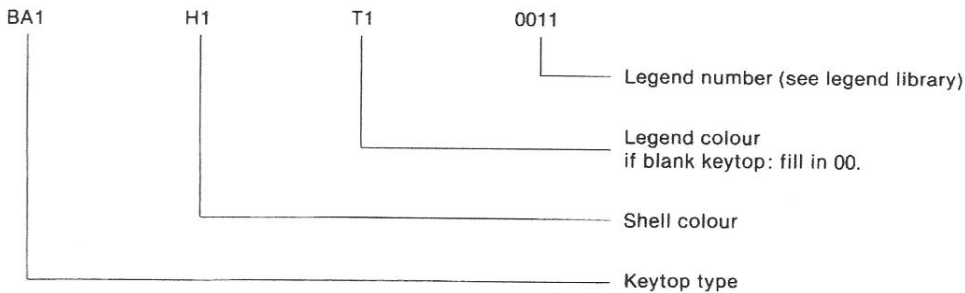

Example: BABR1000000 is a blank keytop 1x1.5 unit, red colour.

# STANDARD LEGEND LIBRARY

Stock items in standard colour combination.

	0	1	2	3	4	5	6	7	8	9
000		1	2	3	4	5	6	7	8	9
001	A	B	C	D	E	F	G	H	I	J
002	K	L	M	N	O	P	Q	R	S	T
003	U	V	W	X	Y	Z	[ ]	[ ]	[ ]	[ ]
004	[ ]	[ ]	[ ]	[ ]	[ ]	[ ]	[ ]	[ ]	[ ]	[ ]
005	[ ]	[ ]	[ ]	[ ]	[ ]	[ ]	[ ]	[ ]	[ ]	[ ]
006	[ ]	[ ]	[ ]	[ ]	[ ]	[ ]	[ ]	[ ]	[ ]	[ ]
007	[ ]	[ ]	[ ]	[ ]	[ ]	[ ]	[ ]	[ ]	[ ]	[ ]
008	[ ]	[ ]	[ ]	[ ]	[ ]	[ ]	[ ]	[ ]	[ ]	[ ]
009	[ ]	[ ]	[ ]	[ ]	[ ]	[ ]	[ ]	[ ]	[ ]	[ ]
010	[ ]	[ ]	[ ]	[ ]	[ ]	[ ]	[ ]	[ ]	[ ]	[ ]
011	[ ]	[ ]	[ ]	[ ]	[ ]	[ ]	[ ]	[ ]	[ ]	[ ]
012	[ ]	[ ]	[ ]	[ ]	[ ]	[ ]	[ ]	[ ]	[ ]	[ ]
013	[ ]	[ ]	[ ]	[ ]	[ ]	[ ]	[ ]	[ ]	[ ]	[ ]

# ILLUMINATED KEYTOPS FOR SI, SK AND SH SWITCHES.

## ILLUMINATED KEYTOPS (KR., KS. SERIES) (TOP AND SIDE SURFACES)

Unit: 1x1 unit (KR1, KS1)  
 1x1.5 unit (KR9, KS9)  
 1x2 units (KR2, KS2)

This keytop gives an even light output on top and side surfaces. An angled base can be specified to allow the use of illuminated switches alongside angled SF-SG types giving a common appearance (KS. series).

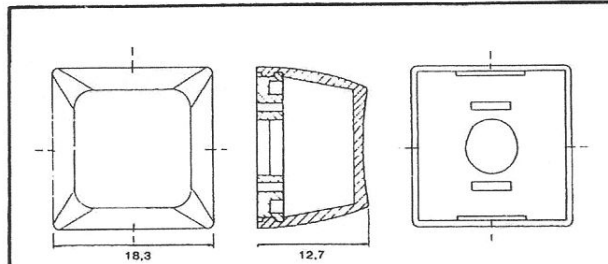

## ILLUMINATED KEYTOPS (KD., KE. SERIES) (TOP SURFACE ONLY)

Unit: 1x1 unit (KD1, KE1)  
 1x1.5 unit (KD9, KE9)  
 1x2 units (KD2, KE2)

These feature a coloured cap with internal opaque spacer (mask) to give light out of top surface only (KD. Series). An angled base can be specified to allow the use of illuminated switches alongside angled SF-SG types giving a common appearance (KE. Series).

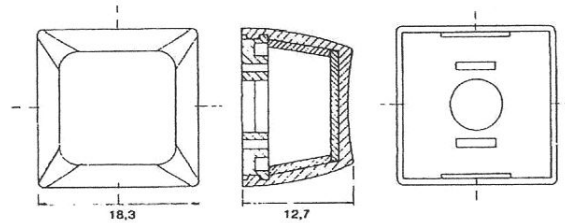

## ILLUMINATED KEYTOPS (KI., KJ. SERIES) (CHANGEABLE LEGEND)

Unit: 1x1 unit (KI1, KJ1)  
 1x1.5 unit (KI9, KJ9)  
 1x2 units (KI2, KJ2)

A special version having transparent (clear) cap and coloured diffuser is available to provide for changeable legends (KI. Series). An angled base can be specified to allow the use of illuminated switches alongside angled SF-SG types giving a common appearance (KJ. Series).

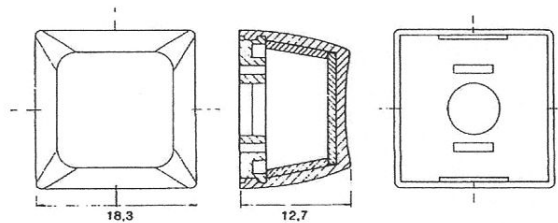

## KZ1 SQUARE CHANGEABLE LEGEND

Legend keytop with coloured diffuser and clear overcap.

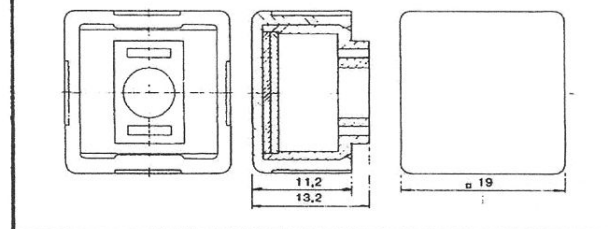



# ILLUMINATED KEYTOPS FOR SIL SWITCHES

## ILLUMINATED KEYTOPS (K21 SERIES) (TOP SURFACE ONLY)

Unit: 1x1 unit (K21)  
1x1.5 unit (K24)  
1x2 units (K27)

Cap colour: blue; yellow; green; orange; red and white

These keytops feature a coloured cap with internal mask to give light out of top surface only.

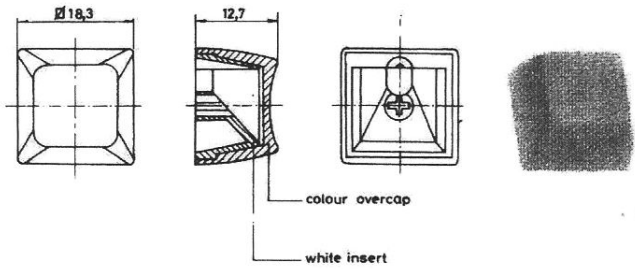

## ILLUMINATED KEYTOPS (K23 SERIES) (CHANGEABLE LEGEND)

Unit: 1x1 unit (K23)(M23)  
1x1.5 unit (K26)  
1x2 units (K29)

Diffuser colours: blue; yellow; green; orange; red and white

These versions, having a clear cap and coloured diffuser, are available to provide changeable legends.

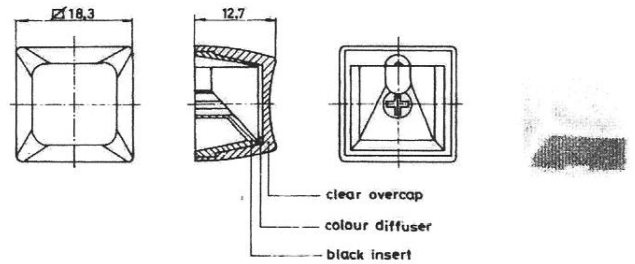

## SQUARE CHANGEABLE LEGEND KY1 SERIES

These keytops are square shaped changeable legend with fitted coloured diffuser and clear plastic overcaps.

KY1 Series - for non-illuminated switches SF; SG and SFL, SGL  
- for illuminated switch SIL

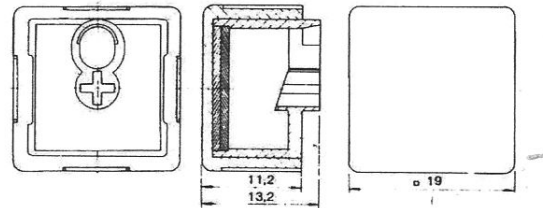

## AVAILABLE COLOURS FOR ILLUMINATED KEYTOPS

blue (B)  
yellow (Y)  
green (G)  
orange (O)  
red (R)  
white (T)

Note: These colours are not equivalent with the colours shown on page 6.

## ORDERING INFORMATION FOR ILLUMINATED KEYTOPS

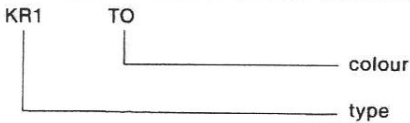

## LED KEYTOP

Designed for use with SIL switches

Available colours: see page 6.

Reference: BC1

