

下視圖
CONNECTIONS (BOTTOM VIEW)

基板端子孔尺寸圖
(P.C.B MOUNTING HOLE DIMENSIONS)

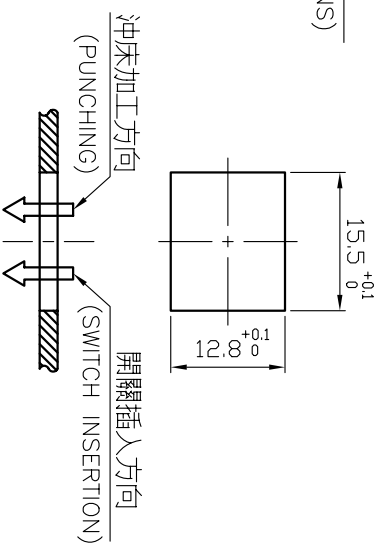

組配用鐵板角孔尺寸圖
(MOUNTING PANEL HOLE DIMENSIONS)

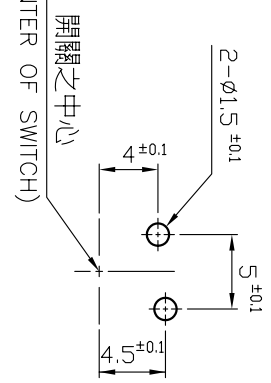
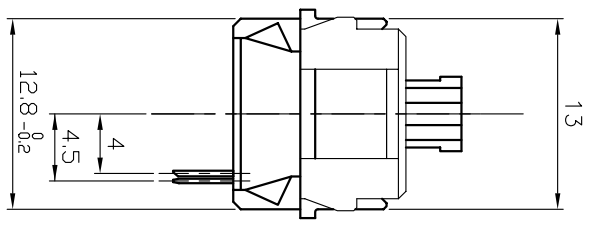
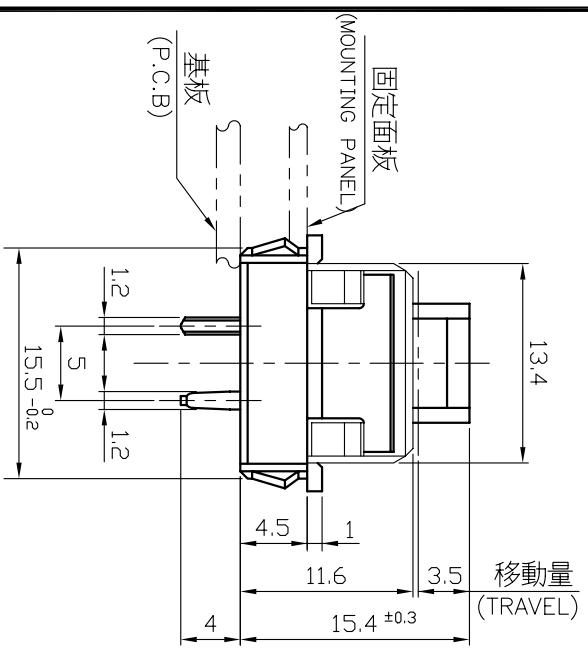

註記: 1.適用製品規格書:SKBM-E01
(PRODUCT SPECIFICATIONS NO:SKBM-E01)

2.動作力:70±25gf
(ACTUATING FORCE IS:70±25gf)

3.柄之顏色為白色
(COLOR OF STEM IS WHITE)

4.組配用鐵板之適用厚度為1.0~1.2mm.
(THE MOUNTING PANEL TO BE 1.0mm TO 1.2mm IN THICKNESS)

5.有CLICK聲。
(WITH CLICK SOUND)

TOLERANCES UNLESS OTHERWISE SPEC.	
BASIC DIMENSIONS	TOLERANCES
UP TO 6	±0.3
ABOVE 6 TO 18	±0.5
ABOVE 18	±0.8
ANGULAR DIMENSIONS	±3°

P/NO.	P/NAME	MATERIAL	SPEC.	TREATMENT	QTY.
		UNIT: mm	SCALE: /		
SYMB	DATE	APPD/CHKD/DSGD			
	Chang 91.07.16	Chang 91.07.16	Chang 91.07.16		
				TITLE: KEYBOARD SWITCH	
				NUMBER: SKBMFA000A	